

Preliminary Data

$V_{CES} = 1200V$

$I_{C\ nom} = 100A / I_{CRM} = 200A$

- V_{CEsat} with positive temperature coefficient
- Low switching losses
- Low inductance case
- Isolated copper baseplate using DBC technology

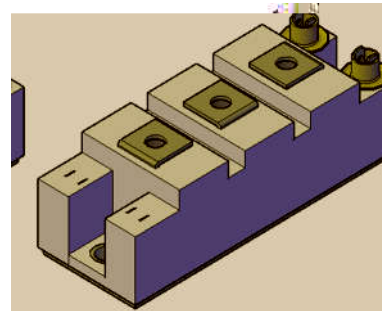

- Welding Machine
- Switching Mode Power Supplies

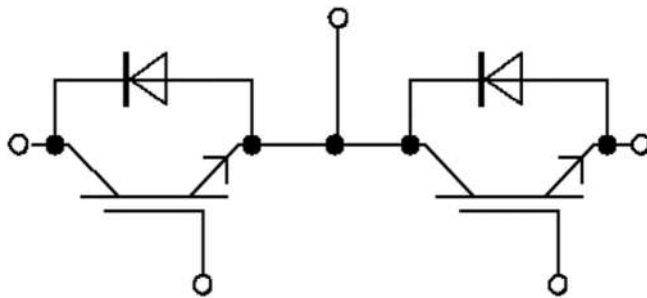

Parameter	Conditions	Symbol	Values	Units

Parameter	Conditions	Symbol	Values			Units
			Min.	Typ.	Max.	

Parameter	Conditions	Symbol	Values	Units

Parameter	Conditions	Symbol	Values			Units
			Min.	Typ.	Max.	

